

Polyform® Aqua Series



**Proudly made by
The Originator of
Modern Plastic Buoys**

POLYFORM® OF NORWAY

The Aqua 3000, configured for fish farming/aquaculture, is made from rotomolded PE outer shell and filled with polystyrene (EPS) foam, guaranteeing a compressive strength of 5 mH₂O and a density of 25kg /m³. The continuous high quality chain is terminated at either end of the buoy by use of hot dip galvanized steel terminating discs that are designed to prevent damage to the buoy. The chain is easily attached by shackle to the anchor line. All wear parts are standard components and can easily be replaced. Aqua-series buoys are designed for surface use and they are equipped with four yellow, daylight reflective tapes for better visibility. Armature and also a radar reflector can be supplied on demand and can also be mounted afterwards.

Polyform AS

Polyform AS is a world leading manufacturer of buoys fenders and floats, and the originator of the modern inflatable plastic buoy. The company is registered in Norway and situated in Ålesund at the north-western coast of Norway, and benefits from being located in one of the world's most innovative maritime environments.

The product range of Polyform AS consists of:

- Inflatable buoys and fenders made from soft Vinyl plastics.
- Purse Seine Floats, buoys and marina fenders made from BACELL closed cell foam.
- Hard-shell buoys and pontoon floats made from PE and filled with foam

POLYFORM AS
Tverrvegen 37
N-6020 Ålesund
Norway

+47 70 17 25 50
+47 70 14 76 36
mail@polyform.no
www.polyform.no

Product information

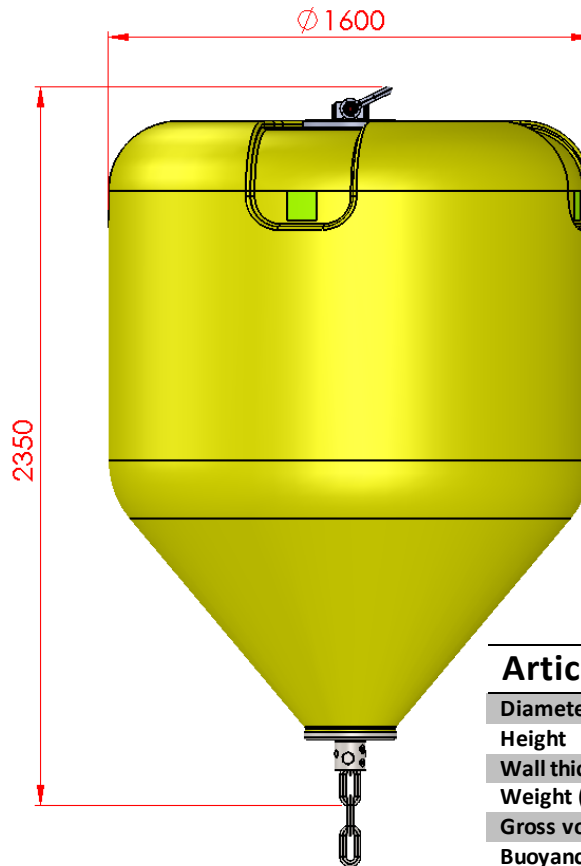

Article number	Aqua 3000
Diameter	1600 mm
Height	2350 mm
Wall thickness	10 mm
Weight (nominal)	235 Kg
Gross volume	3050 L
Buoyancy	2815 Kg
Recommended normal load	1410 Kg

Technical Information

Breaking load Chain	343 KN
Breaking load Shackle	400 KN
Buoy body material description	
Material	LLPE
Hardness, shore D	57
Tensile strength	17,5 MPa
Ultimate Elongation	650%
Recommended min temp.	-25°C
Recommended max temp.	40°C
Temp. not to be exceeded	50°C
Specific gravity	0,94
Foam core material description	
Material	EPS
Density	>25 Kg/m ³
Compressive strength	50 KPa

PRODUCT CERTIFICATE

Complies with the requirements for strength and safety according to **Marine fish farms NS9415** (Norwegian Standard)



For all measurements, weights and other technical data specified in this data sheet, please allow for a deviation of not less than +/-5%. The illustration may deviate from the actual product.